

# Journal of Health Psychology

<http://hpq.sagepub.com>

---

## **Stability of Physical Activity across the Lifespan**

Howard S. Friedman, Leslie R. Martin, Joan S. Tucker, Michael H. Criqui, Margaret L. Kern  
and Chandra A. Reynolds

*J Health Psychol* 2008; 13; 1092

DOI: 10.1177/1359105308095963

The online version of this article can be found at:  
<http://hpq.sagepub.com/cgi/content/abstract/13/8/1092>

---

Published by:



<http://www.sagepublications.com>

**Additional services and information for *Journal of Health Psychology* can be found at:**

**Email Alerts:** <http://hpq.sagepub.com/cgi/alerts>

**Subscriptions:** <http://hpq.sagepub.com/subscriptions>

**Reprints:** <http://www.sagepub.com/journalsReprints.nav>

**Permissions:** <http://www.sagepub.co.uk/journalsPermissions.nav>

**Citations** <http://hpq.sagepub.com/cgi/content/refs/13/8/1092>

# Stability of Physical Activity across the Lifespan

HOWARD S. FRIEDMAN  
*University of California, Riverside, USA*

LESLIE R. MARTIN  
*La Sierra University, USA*

JOAN S. TUCKER  
*RAND Corporation, USA*

MICHAEL H. CRIQUI  
*University of California, San Diego, USA*

MARGARET L. KERN & CHANDRA A. REYNOLDS  
*University of California, Riverside, USA*



*Journal of Health Psychology*  
Copyright © 2008 SAGE Publications  
Los Angeles, London, New Delhi,  
Singapore and Washington DC  
[www.sagepublications.com](http://www.sagepublications.com)  
Vol 13(8) 1092–1104  
DOI: 10.1177/1359105308095963

## Abstract

Physical activity is associated with various health-relevant psychosocial and physiological processes, but activity stability across extended time periods is inadequately understood. This lifespan longitudinal cohort study examined activity levels of 723 males and 554 females. Associations across time were computed and structural equation modeling compared a one factor model and a simplex model. Results showed activity levels are somewhat stable from childhood through middle and late adulthood. Further, a simplex model provided a better fit than a one factor model. Successful models and interventions to improve health will likely require a more nuanced, pattern-sensitive understanding of physical activity across time.

COMPETING INTERESTS: None declared.

ADDRESS. Correspondence should be directed to:  
HOWARD S. FRIEDMAN, Department of Psychology, 900 University Ave,  
University of California, Riverside, CA 92521, USA. [email:  
[Howard.Friedman@ucr.edu](mailto:Howard.Friedman@ucr.edu)]

## Keywords

- *exercise*
- *gender differences*
- *lifespan patterns*
- *physical activity*

THERE IS little doubt that physically active people are at lower risk for disease and premature mortality. Yet the complexity of influences, coupled with limited lifespan data, means the causal pathways are still not well understood. Physical activity is associated with a host of complex contemporaneous and ensuing psychosocial, behavioral, and physiological processes that are characteristic of or lead to better health (US Department of Health and Human Services (USDHHS), 1996). First, physical activity can help control ongoing disease processes like cardiovascular disease and diabetes (Gregg, Gerzoff, Caspersen, Williamson, & Venkat Narayan, 2003; Pedersen & Saltin, 2006), such as by reducing sympathetic nervous system activation and stabilizing blood sugar levels; but people with incipient disease may have more difficulty staying active. Second, physical activity can affect precursors of good health such as normal blood pressure, weight, and blood lipid levels (Pedersen & Saltin, 2006; Whelton et al., 2002); yet the reverse can also be true, with unhealthy precursor conditions like obesity affecting the likelihood of being physically active (Schmitz et al., 2002; USDHHS, 1996). Third, physical activity may have salutary effects on mood and on factors related to social integration (Mutrie & Faulkner, 2004); in turn, people who are less likely to become depressed and who are well integrated into their communities are generally healthier (de Bourdeauhuij & Sallis, 2002; Schaie, House, & Blazer, 1992). Again, causal links are complex, as depression and isolation can significantly affect physical activity levels and other health behaviors. Fourth, physical activity may be a sign of a robust organism, as opposed to one that is biologically or behaviorally impaired. Various underlying factors ("third variables") such as a hearty constitution may affect both activity and health, or detrimental processes may affect both activity levels and likelihood of illness. Thus, the various interrelations and feedback loops among physical activity and health remain poorly understood (Salmon, Owen, Crawford, Bauman, & Sallis, 2003), especially in terms of individual patterns across long periods of time.

Currently, public health policy and government actions endeavor to increase levels of physical activity in the general population (Kahn et al., 2002). For example, teenagers may be encouraged to watch less television and be more active. Yet there is limited evidence that large media campaigns, school campaigns, or community-based

interventions will necessarily improve the health of the population in the long term (Kahn et al., 2002; King, Stokols, Talen, Brassington, & Killingsworth, 2002). Such broad attempts can backfire, be ineffective, or have unintended consequences over time. For example, in the US government campaigns to limit fat consumption, a lean and trim population did not result (Friedman, 2003; Taubes, 2001; Wilfley & Brownell, 1994); instead, as the government educated the public about fat intake, the average person became more obese, for a variety of reasons that are not fully understood. This suggests that greater attention should be directed toward individual patterns, as a complement to epidemiological investigations. The current study employs lifespan data to examine patterns of physical activity from childhood through early old age. A key question involves whether physical activity is a relatively stable personal characteristic rather than mostly a consequence of one's shifting socio-environmental surroundings. That is, if individuals are traveling along relatively stable pathways of activity, then that information should not be ignored when designing exercise interventions and when creating theoretical models of physical activity and health.

More needs to be known about the lifelong patterns of physical activity. Various methods have been used to lay the groundwork for understanding activity patterns and stability, but usually these studies have spanned relatively short to medium periods of time (e.g. Anderssen et al., 1996; Caspersen, Pereira, & Curran, 2000; Glenmark, Hedberg, & Jansson, 1994; Sallis, 2000). Most commonly, activity is tracked across two or three time points, using Pearson or Spearman correlation coefficients, kappa statistics, and multiple regression  $\beta$ -estimates of coefficient stability. Tracking has been assessed across childhood into adolescence (e.g. Anderssen, Wold, & Torsheim, 2005; Janz, Burns, & Levy, 2005), from adolescence into young adulthood (e.g. Boreham et al., 2004; Telama et al., 2005; Trudeau, Laurencelle, & Shepard, 2004), and during a seven-year period of adulthood (de Bourdeauhuij, Sallis, & Vandelanotte, 2002). Other methods for considering activity stability include using baseline characteristics to predict physical activity and fitness several years later (e.g. Glenmark et al., 1994; Hillsdon, Brunner, Guralnik, & Marmot, 2005; Kuh & Cooper, 1992) and relating current activity with retrospective accounts of earlier activity levels (e.g. Frändin, Mellström,

Dundh, & Grimby, 1995; Hirvensalo, Lintenen, & Rantanen, 2000; Taylor, Blair, Cummings, Wun, & Malina, 1999). Retrospective recall may be biased by current activity levels (Lissner, Potischman, Troiano, & Bengtsson, 2004). Prospective studies linking all these time periods are now needed.

Three models of physical activity trajectories are easily distinguished. In an *independence model*, one mostly ignores past activities and assumes that the individual's current biopsychosocial state is key to understanding current level of activity. This model is implicitly assumed by various approaches and intervention studies that do not attend to past activity patterns or individual trajectories. In a *one factor model*, some persons are generally predisposed to be more active than others; that is, a single factor or orientation accounts for much of the individual differences in activity levels across long periods of time. A 'jocks versus nerds' conceptualization fits this model, with one group generally more active. In a *simplex model*, current physical activity is most related to activity during the previous decade or so, but is less predictive across longer time periods. This third model requires attention to long-term trajectories, but places more weight on the recent past in order to best understand activity and optimize interventions. The present study formally compares these three models.

As has been the case in many areas of research, much of the existing long-term physical activity literature reports only on men. Such a focus not only limits generalizing to women, but also limits the understanding of processes (Paffenbarger et al., 1994). Women generally differ from men on psychological issues such as concerns with body image, and on biological issues such as body fat and exercise-relevant hormones. Therefore, this study also ascertains whether activity patterns vary by gender.

## Method

### Participants

The data were derived from the Terman Life-Cycle Study begun by Lewis Terman in 1922 (Friedman et al., 1995; Terman et al., 1925). The sample was originally comprised of 1528 bright, mostly middle class, mostly white boys and girls who were nominated by their teachers as 'gifted' and who were tested to have an IQ of at least 135, and so the sample inherently controls for certain socio-demographic influences. Participants were followed throughout their

lives, with assessments occurring every five to 10 years. The current study, approved by the university Institutional Review Board for Human Subjects, used data from the 1922, 1936, 1940, 1950, 1960, 1972, and 1977 assessments. To be consistent with prior studies and include a single-decade, school-age cohort, participants born before 1904 or after 1915 were excluded ( $N = 155$ ). (Auxiliary analyses that included those participants did not substantially change the results.) Additionally, individuals who died or were lost to follow-up prior to 1936 were excluded ( $N = 96$ ), leaving a final sample of 1277 participants (723 males, 554 females). Missing data reduced the  $N$  in certain analyses. Although the sample is not fully representative of the population at large and should not be carelessly generalized, no other detailed, lifelong studies of these matters exist, and there is no reason to suspect that findings would not be informative about long-term patterns of physical activity in a middle class cohort.

### Measures

Relevant data were originally collected by Terman and his associates at each assessment, but questions were not asked specifically about 'aerobic exercise and physical activity', as might be done today. Indeed, modern notions of aerobic exercise were unknown. Nevertheless, variables exist that can be used to assess each individual's likelihood of involvement in physical activity at each time frame. Any unreliabilities of measurement reduce the likelihood of finding associations.

*Childhood energy level (1922 ratings by adults)* In 1922, parents and teachers rated the participant on a number of traits, and parents reported on their children's current activities. We created a scale of high energy and physical activity, involving preference for games requiring lots of exercise, preference for playing outdoors, and rated physical energy on a 1 to 13 scale (see Friedman et al., 1993 for further details of the ratings by parents and teachers).

*Childhood activity and interests (1922)* In 1922, parents listed participants' 'hobbies or enterprises', and the first three mentions were recorded and coded (see below). Additionally, participants indicated on a 1 to 5 scale (1 = dislike it very much, 5 = like it very much) how much they enjoyed playing games that require lots of exercise. These ratings were averaged to indicate childhood interest in being physically active.

**Adult physical activity (1936, 1940, 1950, 1960, and 1972)** Beginning in 1936, participants freely listed: 'Avocational activities and hobbies in recent years (such as sports, music, art, writing, aviation, photography, collections, gardening, wood work, etc.)'. The first four mentions were recorded and coded to create dichotomous and continuous measures of activity and intensity for each year (see section on coding, below).

**Older age activity (1977)** In 1977, when participants were, on average, 67 years old, individuals were asked about their level of participation in various activities. The information gathered at this assessment was different from that of earlier adult assessments in that activities were listed for the subjects (as opposed to free-response) and subjects indicated whether they currently participated in each activity 'never', 'seldom', 'occasionally', or 'frequently'. Responses were coded (see below) and averaged to create a total older age activity score. The 1977 sample was smaller than the earlier samples from this project, as a number of participants had died by this point or were otherwise unavailable to complete the questionnaires.

**Coding** For the 1922, 1936, 1940, 1950, 1960, and 1972 assessments, three trained judges assigned a dichotomous activity score to each participant, indicating whether or not he or she reported engaging in at least one activity involving substantial exertion (e.g. tennis, hiking). This dichotomous categorization removes the possibility that an individual who listed several different physical activities, but who did each only occasionally, would receive a higher score than someone who diligently pursued only one or two such activities. The inter-rater reliabilities (mean phi) were: PA 1922:  $\phi = .92$ ; PA 1936:  $\phi = .95$ ; PA 1940:  $\phi = .95$ ; PA 1950:  $\phi = .94$ ; PA 1960:  $\phi = .92$  and PA 1972:  $\phi = .95$ . In addition, three trained judges rated the level of activity required for pastimes on a 0 to 6 scale (0 = no activity, 1 = little energy required for activity, 6 = highly active). Responses were then scored and summed to create an overall activity intensity score for that year (in 1922 the first three mentions were used; in 1936, 1940, 1950, 1960, and 1972 the first four mentions were used). Highly physical activities included active or competitive sports (e.g. baseball, football, track, tennis) and outdoor activities (e.g. horseback riding, hunting, fishing, bicycling). Moderate activities

included active hobbies such as woodworking, gardening, carpentry, folk dancing, and ballroom dancing. Sedentary activities included hobbies such as card play, board games, stamp collecting, reading, sewing, studying, and activities that involved leaving the home but no vigorous exercise (e.g. attending the theater, religious activities, and club meetings). The average inter-rater reliabilities for the activity scales were: 1922 activity (parent-rated):  $r = .85$ ; 1936 activity:  $r = .78$ ; 1940 activity:  $r = .78$ ; 1950 activity:  $r = .84$ ; 1960 activity:  $r = .82$ ; and 1972 activity:  $r = .85$ . As there was no way to ascertain frequency of participation in various activities, such measures are probably not as reliable as a contemporaneous daily measure of activity and may underestimate effects.

For the 1977 assessment, we identified five categories of activities rated as requiring a high level of physical activity. These were: (1) competitive sports; (2) noncompetitive physical sports; (3) working on active hobbies (includes gardening); (4) home repairs and maintenance; and (5) physical self-improvement (diet & exercise). Scoring for each category ranged from 0 (never) to 3 (frequently) and individual scores were computed based on the average of these five items (inter-rater reliability = .94).

### Statistical analyses

Descriptive information and correlational analyses (Pearson, point-biserial, or phi, as appropriate) were computed to ascertain the associations of physical activity levels among childhood energy (1922), dichotomous indicators of physical activity (1922, 1940, 1950, 1960, 1972), activity intensity (1922, 1936, 1940, 1950, 1960, 1972), and older age activity (1977).

To consider stability of activity intensity across adulthood (1936 through 1972), a one factor model and a simplex model were compared using structural equation modeling methods. In the one factor model, an overall physical activity trait drives physical activity behavior at different measurement occasions; observed differences across time are due to measurement errors and random variation, separate from time (Marsh, 1993). In contrast, a simplex model is applicable in a longitudinal series where the factor variance is carried from occasion to occasion, new sources of variance contribute at each occasion, and correlations decrease with increasing distance between time points (Guttman, 1954; Jöreskog, 1970). Specifically, a quasi-Weiner simplex model with equal error

variances was estimated, which is most appropriate when measurements include a degree of error (Jöreskog, 1970, 1979). (Constraining error variances to equality is a more restrictive model that can be estimated when the units of measurement are the same across all occasions; Jöreskog, 1979.) To best represent the transmission and incoming variances across the years, latent dummy variables were added to create approximately evenly spaced five year intervals.

Descriptive and correlational analyses were performed using SAS 9.1 software, and SEM modeling was performed using Mx 1.55 software (Neale, Boker, Xie, & Maes, 2004). Mx allows missing data to be handled by estimating a structured model of the means from the raw data, provided that good start values are defined (Neale et al., 2004). To obtain proper start values, covariances among the five adult physical activity variables were computed from the complete cases (with activity ratings across all five (1936–1972) measurement occasions;  $N = 491$ ), and the two competing models were estimated and compared. Estimated values were then used as start values for the structured means model, using the raw data from all cases ( $N = 1277$ ).

Several fit indices were used to assess model fit. Chi-square is one of the most commonly used indicators, but it is relatively sensitive to sample size (Loehlin, 2004), therefore several other indices were also considered. RMSEA (root mean square error approximation index) is a population-based model that is not affected by sample size, and offers confidence intervals. A RMSEA fit of less than .08 is considered good and .08 to .10 is acceptable. The AIC (Akaike's Information Criteria) estimates model fit while adjusting for parsimony. In Mx, AIC is calculated as  $\chi^2 - 2$  d.f. (Neale et al., 2004); smaller values indicate a better fit. The RMSEA and AIC were compared to determine the better fitting model, as the two models were not nested.

## Results

The participants were, on average, born in 1910 ( $SD = 2.89$  years), and were 11 years old at the first assessment. Data were available for 1157 participants in 1922, 922 participants in 1936, 1031 participants in 1940, 1144 participants in 1950, 968 participants in 1960, 793 participants in 1972, and 712 participants in 1977.

### *Associations from childhood through the lifespan*

First, to test the independence model, we investigated whether energy and activity levels evidence some degree of stability from childhood through older adulthood by examining the associations among childhood energy, the dichotomous indicators of activity, and older age activity. The inter-correlations are shown in Table 1 (Pearson, point-biserial, or phi, as appropriate). As can be seen, there is some consistency of physical activity levels throughout the lifespan. Interestingly, even parental ratings of energy and activities around age 11 (in 1922) were predictive of self-reported avocational activity decades later (see first two columns of correlations). For example, the parents' ratings of their boys' energy levels in 1922 was correlated  $r_{pb} = .17$  ( $N = 625$ ,  $p < .001$ ) with our codings of their avocational activities in 1950. Because the various assessments were originally designed as measures of interests, characteristics, and hobbies rather than as precise measures of activity, there is considerable unreliability of measurement; further, there are situational constraints on activities reported. Thus, the true inter-correlations of physical activity across the lifespan are likely considerably higher. This finding of some stability in energy or activity levels has not been previously demonstrated with full prospective lifespan data.

We then considered the associations for activity intensity, using the more specific rating scores for each activity mentioned. These inter-correlations are displayed in Table 2. Ratings generally followed the same patterns as the dichotomous indicators of activity. Childhood energy and activity ratings correlated with adult activity.

### *Stability of activity: Comparing one factor and simplex models*

An examination of the inter-item correlations suggests a simplex model; that is, there were generally higher correlations for activity measured at closer points in time. Note that these are contemporaneous measures at each time period, not subject to retrospective biases. To test the longitudinal associations over time, structural equation modeling (SEM) was used to compare a one factor model and a simplex model using activity intensity scores from 1936, 1940, 1950, 1960, and 1972. Across these periods, 491 participants (39.5%) completed all five measurement occasions, 359 participants completed four occasions, 205 completed three occasions,

Table 1. Correlations of activity from childhood through adulthood, using conservative (dichotomous) indicators

Variable	Childhood energy (1922) <sup>a</sup>	1922 activity	1936 activity	1940 activity	1950 activity	1960 activity	1972 activity
1922 activity <sup>b</sup>							
M	.14 (1154) ***						
F	.21 (653) ***						
1936 activity <sup>b</sup>							
M	.07 (501)	.12 (782) ***					
F	.13 (824) ***	.16 (436) **					
1940 activity <sup>b</sup>							
M	.19 (463) ***	.06 (346)	.21 (469) ***				
F	.08 (361)	.12 (653) **	.21 (256) ***				
1950 activity <sup>b</sup>							
M	.15 (697) ***	.13 (375) *	.20 (213) **	.11 (578) **			
F	.23 (403) ***	.07 (278)	.10 (718) **	.14 (391) **			
1960 activity <sup>b</sup>							
M	.08 (294)	.11 (1036) ***	.10 (382)	.04 (287)	.30 (899) ***		
F	.17 (625) ***	.17 (583) ***	.10 (336)	.09 (579) *	.25 (492) ***		
1972 activity <sup>b</sup>							
M	.07 (480)	.01 (453)	.10 (587) *	.06 (327)	.32 (407) ***	.25 (696) ***	
F	.10 (891) **	.10 (842) **	.11 (300) *	.08 (252)	.21 (759) ***	.22 (370) ***	
1977 (older age) activity <sup>c</sup>							
M	.09 (491) *	.07 (462)	.06 (287)	.09 (494) *	.21 (404) ***	.22 (326) ***	.32 (634) ***
F	.13 (400) *	.10 (380) *	.12 (553) **	.11 (267)	.17 (355) **	.24 (628) ***	.32 (330) ***
1977 (older age) activity <sup>c</sup>							
M	-.001 (760)	.06 (716)	.15 (288) *	.04 (227)	.22 (365) ***	.21 (333) ***	.27 (304) ***
F	.02 (402)	.05 (380)	.15 (449) **	.15 (444) **	.16 (324) **	.24 (295) ***	
1977 (older age) activity <sup>c</sup>							
M	-.001 (358)	.03 (336)	.15 (223) *	.22 (237) ***			
F	.07 (681)	.15 (646) ***	.13 (226) *	.05 (207)			
1977 (older age) activity <sup>c</sup>							
M	.16 (362) **	.14 (344) **					
F	.003 (319)	.12 (302) *					

Note: N indicated in parentheses (n). M = males; F = females. Correlations are Pearson, point-biserial, or phi, as appropriate. Higher values indicate more energy or a higher activity level

<sup>a</sup> Combined parent-teacher ratings on physical energy level (1 = extreme lack of energy, 13 = extraordinary amount of physical energy) <sup>b</sup> Dichotomous activity indicator (1 = active, 0 = inactive) <sup>c</sup> Average participation in five physically active pastimes (0 = never, 3 = frequently) \**p* < .05; \*\**p* < .01; \*\*\**p* < .001

Table 2. Inter-correlations of activity intensity level, using the cumulative intensity ratings required for each activity

Variable	1	2	3	4	5	6	7	8	9
1. 1922 Childhood energy <sup>a</sup>	1.00 (1228)								
M	1.00 (698)								
F	1.00 (530)								
2. 1922 intensity <sup>b</sup>	.15 (1148) ***	1.00 (1157)							
M	.14 (647) ***	1.00 (655)							
F	.16 (501) ***	1.00 (502)							
3. Child interest (1922) <sup>c</sup>	.65 (1090) ***	.12 (1028) ***	1.00 (1100)						
M	.66 (620) ***	.13 (580) **	1.00 (627)						
F	.65 (470) ***	.13 (448) **	1.00 (473)						
4. 1936 intensity <sup>d</sup>	.07 (895) *	.07 (846) *	.09 (804) *	1.00 (922)					
M	.09 (516) *	.06 (484)	.15 (464) **	1.00 (530)					
F	.05 (379)	.08 (362)	-.003 (340)	1.00 (392)					
5. 1940 intensity <sup>d</sup>	.11 (987) ***	.07 (934) *	.09 (888) **	.41 (781) ***	1.00 (1031)				
M	.13 (561) **	.09 (530) *	.11 (507) **	.48 (450) ***	1.00 (584)				
F	.10 (426) *	.05 (404)	.06 (381)	.30 (331) ***	1.00 (447)				
6. 1950 intensity <sup>d</sup>	.07 (1101) *	.01 (1037)	.08 (988) **	.27 (834) ***	.37 (953) ***	1.00 (1144)			
M	.12 (623) **	.04 (585)	.16 (560) ***	.31 (474) ***	.38 (540) ***	1.00 (644)			
F	.005 (478)	.01 (452)	-.04 (428)	.21 (360) ***	.37 (413) ***	1.00 (500)			
7. 1960 intensity <sup>d</sup>	.04 (930)	-.01 (880)	.01 (845)	.19 (722) ***	.26 (824) ***	.20 (684) ***	1.00 (968)		
M	.02 (517)	.01 (487)	-.004 (471)	.23 (402) ***	.25 (456) ***	.36 (516) ***	1.00 (537)		
F	.09 (413)	.03 (393)	.02 (374)	.12 (320) *	.26 (368) ***	.32 (416) ***	1.00 (431)		

(Continued)



Table 2. (Continued)

Variable	1	2	3	4	5	6	7	8	9
8. 1972 intensity <sup>d</sup>									
M	-.03 (760)	.03 (718)	.01 (686)	.09 (600) *	.36 (932) ***	.23 (759) ***	.28 (720) ***	1.00 (793)	
F	-.02 (402)	.06 (381)	.01 (365)	.15 (321) **	.26 (366) ***	.23 (405) ***	.33 (383) ***	1.00 (419)	
	-.03 (358)	-.02 (337)	.002 (321)	.01 (279)	.14 (318) *	.22 (354) ***	.23 (337) ***	1.00 (374)	
9. 1977 (older age) activity <sup>e</sup>									
M	.07 (681)	.05 (649)	.12 (619) **	.16 (543) ***	.20 (620) ***	.30 (687) ***	.29 (649) ***	.32 (634) ***	1.00 (712)
F	.16 (362) **	.08 (347)	.21 (329) ***	.27 (288) ***	.22 (328) ***	.34 (365) ***	.31 (344) ***	.35 (330) ***	1.00 (375)
	.00 (319)	.09 (302)	.01 (290)	.03 (255)	.21 (292) ***	.23 (322) ***	.21 (305) ***	.28 (304) ***	1.00 (337)

Note: N indicated in parentheses (n). M = males; F = females. Higher values indicate more energy or higher energy intensity

<sup>a</sup> Combined parent-teacher ratings on physical energy level (1 = extreme lack of energy, 13 = extraordinary amount of physical energy)

<sup>b</sup> Parent free-response of child's hobbies and activities (sum of first three mentions, 0 = no energy required for activity, 6 = high level of energy required for activity)

<sup>c</sup> Child rating of interest in physically active pastimes (1 = dislike very much, 5 = like very much)

<sup>d</sup> Participant free-response of interests and activities (sum of first four mentions, 0 = no energy required for activity, 6 = high level of energy required for activity)

<sup>e</sup> Average participation in five physically active pastimes (0 = never, 3 = frequently)

\**p* < .05; \*\**p* < .01; \*\*\**p* < .001

130 completed two occasions, and 92 completed one occasion.

First, we evaluated the two models using complete cases (*N* = 491). Although both the one factor and simplex models fit the data significantly better than the null (or independence) model ( $\Delta\chi^2(9) = 282.69$  and  $314.10$ , respectively, both *ps* < .001), the fit of the one factor model was inadequate (RMSEA = .11 (95% confidence interval .08, .15)). The simplex model did provide a good fit to the data (RMSEA = .00 (.00, .06)). Using the AIC criteria, the simplex model was by far the best fitting model (AIC<sub>null</sub> = 290.48; AIC<sub>1 factor</sub> = 25.79; AIC<sub>simplex</sub> = -5.62). Figure 1 shows the paths and path estimates for the one factor model, and Figure 2 shows the paths and path estimates for the simplex model.

Second, the one factor and simplex models were estimated separately for males and females, using complete cases (*N*<sub>males</sub> = 265 and *N*<sub>females</sub> = 226). For males, the one factor model again failed to provide a good fit (RMSEA = .15 (.11, .20); AIC = 24.81), whereas the simplex model did provide a good fit (RMSEA = .04 (.00, .10); AIC = -2.82). For females, both the one factor and simplex models provided an acceptable fit to the data (RMSEA<sub>1 factor</sub> = .05 (.00, .11), AIC<sub>1 factor</sub> = -2.58; RMSEA<sub>simplex</sub> = .00 (.00, .09), AIC<sub>simplex</sub> = -5.59), but the simplex model was superior to the one factor model, as indicated by the RMSEA and AIC values (also note that the RMSEA upper 95% confidence interval for the one factor model is greater than .10, suggesting a suboptimal fit).

Third, models of the structured mean values and covariances were estimated by including the raw data from all non-missing responses (*N* = 1277). (Detailed descriptive information, model fit indices, and expected variances for complete and incomplete cases are available from the author upon request.) Resulting pathway estimates did not vary significantly between the complete and incomplete cases, and estimates were consistent with complete case values for both males and females. This indicates that the data were not biased by the patterns displayed by the complete cases. Overall, the pattern of results suggests that new variance entered at each time point, reflecting new sets of influences (e.g. health or illness, changes in hobbies or occupations, greater leisure time).

## Discussion

Interventions that increase levels of physical activity in the short term in the general population are

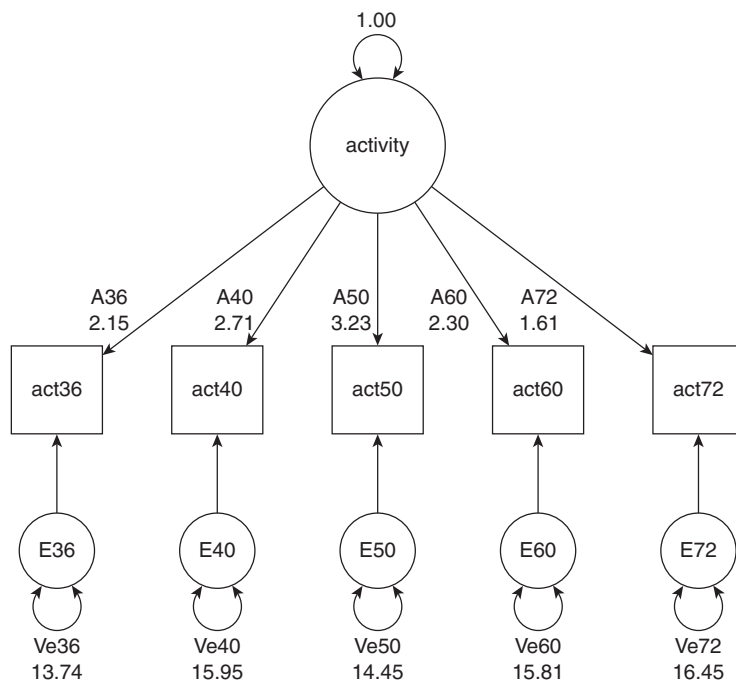

Figure 1. Path estimates for one factor model, complete cases ( $N = 491$ ).

sometimes seen as a proxy to increasing long-term health and longevity, but such inferences are not valid if the effects are not long-lasting and the relevant causal mechanisms are not affected. The multiple pathways linking activity and health, and the complexities of human health, should provoke a subtle and nuanced approach that acknowledges individual differences. The question addressed in this study was whether there is consistency in physical activity levels from childhood through young and middle adulthood and into old age, and whether consistency is better captured by a single general factor or a simplex model.

Despite the limits of an archival cohort study, significant associations emerged across nearly six decades. Active, energetic children tended to become active, energetic adults, and in turn tended to remain active. Precise causal pathways remain unknown, but it may be prudent to consider temperamental factors (genetics, hormones, and early development) or personality factors (individual differences in biopsychosocial patterns of responding) to better understand adult inactivity and design better interventions aimed at young, middle-aged, and older adults. Just as a health professional would not

ignore a life-long predisposition to obesity or heart disease when designing an intervention for these conditions, life pathways of physical activity should also be carefully considered when designing activity interventions.

In addition to rejecting the idea that physical activity can be independently considered at each stage of life, our coding and analyses of the lifespan Terman data support a simplex model. That is, it is not enough to know that some individuals are and tend to remain more active than others; rather, it is better to know their activity levels in the past decade or so. Nevertheless, it is remarkable that childhood energy levels and activity interests are somewhat predictive of activity-relevant hobbies many decades later.

In terms of gender, the patterns of findings were generally similar for males and females, paralleling results others have found for activity in elderly men and women (Langer, Klauber, Criqui, & Barrett-Connor, 1994), but there were some larger correlations for males; this may have been due to the restrictions on the physical activity of females during the 20th century, ranging from traditional gender roles (with greater constraints on recreational activities) to childrearing duties.

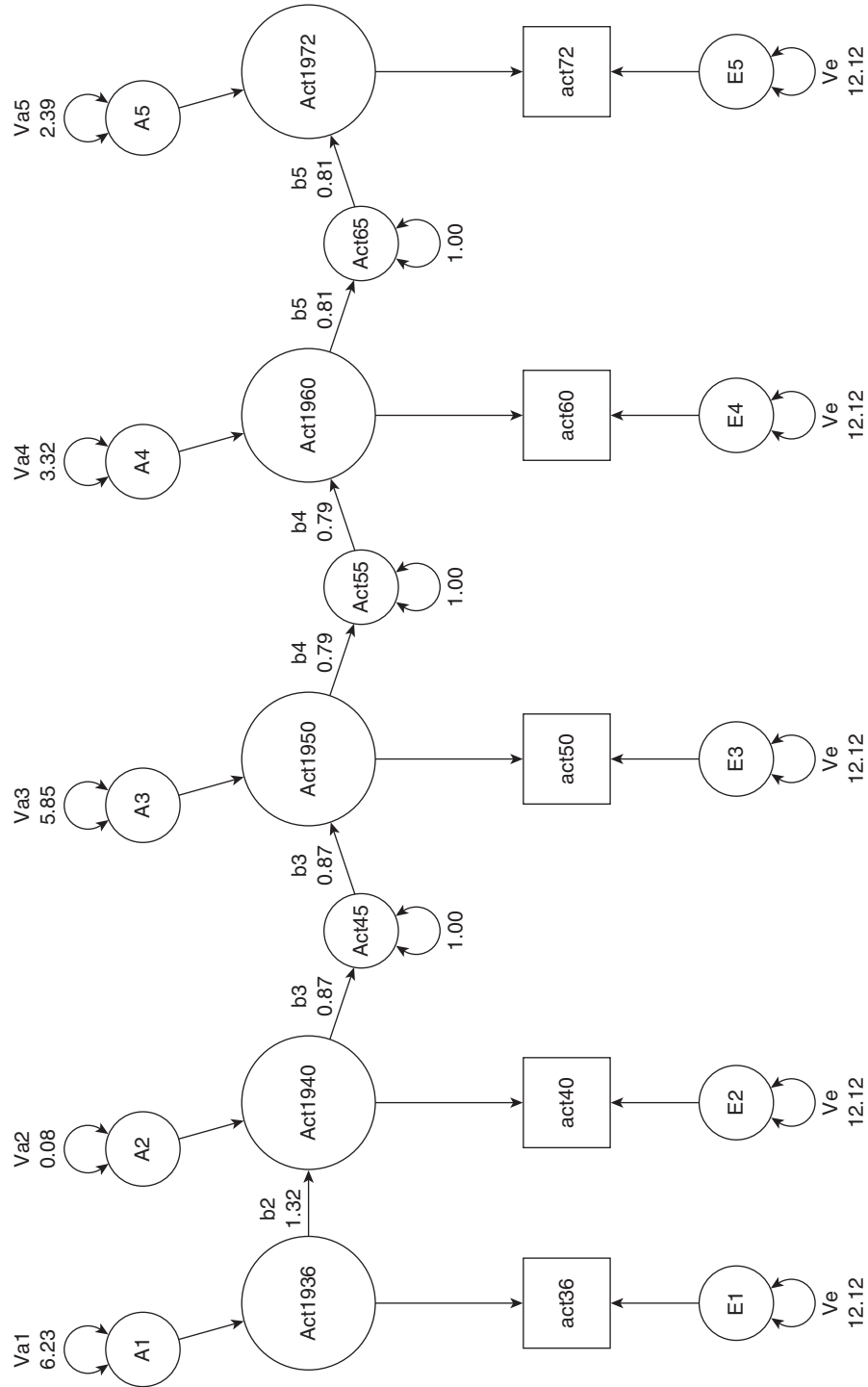

Figure 2. Path estimates for simplex model, complete cases (N = 491).

Few lifespan longitudinal studies of individual differences are based on a true random sample of the population, for a variety of reasons of focus, cost, availability, and time frame; the important question of generality that arises should not be whether any results are fully generalizable (since they usually are not); rather, the focus should be on the likely limits on generality, and the purposes for which the results are best employed. The homogeneous nature of this sample on intelligence obviously restricts the range on intellect, but our published studies of the past decade show that there is a more than adequate range of most individual differences. The Terman data cannot be directly generalized and used for precise estimates of population effect sizes. Nevertheless, the finding of consistency in activity patterns (despite unreliabilities of measurement) is likely true throughout the population and suggests that adolescents and young adults already differ from each other in stable ways relevant to physical activity across the full lifespan. This has not been previously documented across such a long time period.

Because the links among physical activity and various biopsychosocial factors are complex, the present results provide a backdrop for more detailed mediational analyses of activity and health. It is well established that physical activity can be a cause, a consequence, and a correlate of a host of healthy and unhealthy states, traits, and behaviors at different points in life. Future research might focus more on the long-term pathways to better or worse health, the role played by physical activity in various stages of life, and the *processes* of these pathways (Friedman, 2007). The present study, spanning nearly six decades, suggests there are very long-term consistencies in levels of physical activity, a finding that likely has implications for understanding the complex causal interrelations of physical activity and health.

## References

- Anderssen, N., Jacobs, D. R., Jr, Sidney, D. R., Bild, D. E., Sternfeld, B., Slattery, M. L., & Lewis, B. (1996). Stability, change and secular trends in physical activity patterns in young adults: A 7-year longitudinal follow-up in CARDIA. *American Journal of Epidemiology*, *143*, 351–362.
- Anderssen, N., Wold, B., & Torsheim, T. (2005). Tracking of physical activity in adolescence. *Research Quarterly for Exercise and Sport*, *76*, 119–129.
- Boreham, C., Robson, P. J., Gallagher, A. M., Cran, G. W., Savage, J. M., & Murray, L. J. (2004). Tracking of physical activity, fitness, body composition and diet from adolescence to young adulthood: The young hearts project, Northern Ireland. *International Journal of Behavioral Nutrition and Physical Activity*, *1*, 14 [online].
- Caspersen, C. J., Pereira, M. A., & Curran, K. M. (2000). Changes in physical activity patterns in the United States by sex and cross-sectional age. *Medicine and Science in Sports & Exercise*, *32*, 1601–1609.
- De Bourdeaudhuij, I., & Sallis, J. (2002). Relative contribution of psychosocial variables to the explanation of physical activity in three population-based adult samples. *Preventive Medicine: An International Journal Devoted to Practice & Theory*, *34*, 279–288.
- De Bourdeaudhuij, I., Sallis, J., & Vandelanotte, C. (2002). Tracking and explanation of physical activity in young adults over a seven-year period. *Research Quarterly for Exercise & Sport*, *73*, 376–385.
- Frändin, K., Mellström, D., Dunth, V., & Grimby, G. (1995). A life span perspective on patterns of physical activity and functional performance at the age of 76. *Gerontology*, *41*, 109–120.
- Friedman, H. S. (2003). Healthy life-style across the life-span: The heck with the Surgeon General! In J. Suls & K. Wallston (Eds.), *Social psychological foundations of health and illness* (pp. 3–21). Boston, MA: Blackwell Publishing.
- Friedman, H. S. (2007). Personality, disease, and self-healing. In H. S. Friedman & R.C. Silver (Eds.), *Foundations of health psychology* (pp. 172–199). New York: Oxford University Press.
- Friedman, H. S., Tucker, J. S., Schwartz, J. E., Tomlinson-Keasey, C., Martin, L. R., Wingard, D. L., & Criqui, M. H. (1995). Psychosocial and behavioral predictors of longevity: The aging and death of the 'Termites'. *American Psychologist*, *50*, 69–78.
- Friedman, H. S., Tucker, J., Tomlinson-Keasey, C., Schwartz, J., Wingard, D., & Criqui, M. H. (1993). Does childhood personality predict longevity? *Journal of Personality and Social Psychology*, *65*, 176–185.
- Glenmark, B., Hedberg, G., & Jansson, E. (1994). Prediction of physical activity in adulthood by physical characteristics, physical performance, and physical activity in adolescence: An 11 year follow-up study. *European Journal of Applied Physiology*, *69*, 530–538.
- Gregg, E. W., Gerzoff, R. B., Caspersen, C. J., Williamson, D. F., & Venkat Narayan, K. M. (2003). Relationship of walking to mortality among US adults with diabetes. *Archives of Internal Medicine*, *163*, 1440–1447.
- Guttman, L. (1954). A new approach to factor analysis: The radix. In P. F. Lazarsfeld (Ed.), *Mathematical thinking in the social sciences* (pp. 258–348). New York: Columbia University Press.
- Hillsdon, M. M., Brunner, E. J., Guralnik, J. M., & Marmot, M. G. (2005). Prospective study of physical activity and physical function in early old age. *American Journal of Preventive Medicine*, *28*, 245–250.

- Hirvensalo, M., Lintenen, T., & Rantanen, T. (2000). The continuity of physical activity: A retrospective and prospective study among older people. *Scandinavian Journal of Medicine Science in Sports*, *10*, 37–41.
- Janz, K. F., Burns, T. L., & Levy, S. M. (2005). Tracking of activity and sedentary behaviors in childhood: The Iowa bone development study. *American Journal of Preventive Medicine*, *29*, 171–178.
- Jöreskog, K. G. (1970). Estimation and testing of simplex models. *British Journal of Mathematical and Statistical Psychology*, *23*, 121–145.
- Jöreskog, K. G. (1979). Analyzing psychological data by structural analysis of covariance matrices. In K. G. Jöreskog & S. Sörbom (Eds.), *Advances in factor analysis and structural equation models* (pp. 45–100). Cambridge, MA: Abt Books.
- Kahn, E. B., Ramsey, L. T., Brownson, R. C., Heath, G. W., Howze, E. H., & Powell, K. E. et al. (2002). The effectiveness of interventions to increase physical activity: A systematic review. *American Journal of Preventive Medicine*, *22*, 73–106.
- King, A. C., Stokols, D., Talen, E., Brassington, G. S., & Killingsworth, R. (2002). Theoretical approaches to the promotion of physical activity: Forging a transdisciplinary paradigm. *American Journal of Preventive Medicine* [Special Issue: Innovative approaches to understanding and influencing physical activity], *23*, 15–25.
- Kuh, J., & Cooper, C. (1992). Physical activity at 36 years: Patterns and childhood predictors in a longitudinal study. *Journal of Epidemiology and Community Health*, *46*, 114–119.
- Langer, R. D., Klauber, M. R., Criqui, M. H., & Barrett-Connor, E. L. (1994). Exercise and survival in the very old. *American Journal of Geriatric Cardiology*, *3*, 24–34.
- Lissner, L., Potischman, N., Troiano, R., & Bengtsson, C. (2004). Recall of physical activity in the distant past: The 32-year follow-up of the prospective population study of women in Göteborg, Sweden. *American Journal of Epidemiology*, *159*, 304–307.
- Loehlin, J. C. (2004). *Latent variable models: An introduction to factor, path, and structural analysis*, 4th edn. New Jersey: Lawrence Erlbaum Associates.
- Marsh, H. W. (1993). Stability of individual differences in multiwave panel studies: Comparison of simplex models and one-factor models. *Journal of Educational Measurement*, *30*, 157–183.
- Mutrie, N., & Faulkner, G. (2004). Physical activity: Positive psychology in motion. In P. A. Linley & S. Joseph (Eds.), *Positive psychology in practice* (pp. 146–164). New Jersey: Wiley.
- Neale, M., Boker, S., Xie, G., & Maes, H. (2004). Mx: Statistical modeling (Version 1.55), Richmond, VA.
- Paffenbarger, R. S., Kampert, J. B., Lee, I., Hyde, R. T., Leung, R. W., & Wing, A. L. (1994). Changes in physical activity and other lifeway patterns influencing longevity. *Medicine & Science in Sports & Exercise*, *26*, 857–865.
- Pedersen, B. K., & Saltin, B. (2006). Evidence for prescribing exercise as therapy in chronic disease. *Scandinavian Journal of Medicine and Science in Sports*, *16*, 3–63.
- Sallis, J. F. (2000). Age-related decline in physical activity: A synthesis of human and animal studies. *Medicine and Science in Sports & Exercise*, *32*, 1598–1600.
- Salmon, J., Owen, N., Crawford, D., Bauman, A., & Sallis, J. F. (2003). Physical activity and sedentary behavior: A population-based study of barriers, enjoyment, and preference. *Health Psychology*, *22*, 178–188.
- Schaie, K. W., House, J. S., & Blazer, D. (Eds.). (1992). *Aging, health behaviors, and health outcomes*. Hillsdale, NJ: Lawrence Erlbaum Associates.
- Schmitz, K. H., Lytle, L. A., Phillips, G. A., Murray, D. M., Birnbaum, A. S., & Kubik, M. Y. (2002). Psychosocial correlates of physical activity and sedentary leisure habits in young adolescents: The Teens Eating for Energy and Nutrition at School study. *Preventive Medicine: An International Journal Devoted to Practice & Theory*, *34*, 266–278.
- Taubes, G. (2001). The soft science of dietary fat. *Science*, *291*, 2536–2545.
- Taylor, W. C., Blair, S. N., Cummings, S. S., Wun, C. C., & Malina, R. M. (1999). Childhood and adolescent physical activity patterns and adult physical activity. *Medicine and Science in Sports & Exercise*, *31*, 118–123.
- Telama, R., Yang, X., Vikari, J., Välimäki, I., Wanne, O., & Raitakari, O. (2005). Physical activity from childhood to adulthood: A 21-year tracking study. *American Journal of Preventive Medicine*, *28*, 267–273.
- Terman, L. M., Baldwin, B. T., Bronson, E., DeVoss, J. C., Fuller, F., Goodenough, F. L. et al. (1925). *Genetic studies of genius, I: Mental and physical traits of a thousand gifted children*. Stanford, CA: Stanford University Press.
- Trudeau, F., Laurencelle, L., & Shepard, R. J. (2004). Tracking of physical activity from childhood to adulthood. *Medicine and Science in Sports & Exercise*, *36*, 1937–1943.
- US Department of Health and Human Services (USDHHS). (1996). *Physical activity and health: A report of the Surgeon General*. Washington, DC: US Department of Health and Human Services.
- Whelton, P. K., He, J., Appel, L. J., Cutler, J. A., Havas, S., Kotchen, T. A. et al. (2002). Primary prevention of hypertension: Clinical and public health advisory from the national high blood pressure education program. *Journal of the American Medical Association*, *288*, 1882–1888.
- Wilfley, D. E., & Brownell, K. D. (1994). Physical activity and diet in weight loss. In R. K. Dishman (Ed.), *Advances in exercise adherence* (pp. 361–393). Champaign, IL: Human Kinetics Publishers.

### **Author biographies**

HOWARD S. FRIEDMAN, PhD (Principal Investigator, Grant AG08825 from the National Institute on Aging) is Distinguished Professor of Psychology at the University of California, Riverside. Parts of the data derive from the Terman Life-Cycle Study, begun by Lewis Terman. This article is one of a series developed from a large-scale, multi-year, multidisciplinary project on lifespan predictors of health and longevity, and although all relevant findings are included in each article to the extent feasible, the complexity, scope, and diversity of focus precludes simple integration. Reviews or meta-analyses using these findings should consult our related articles, dating from 1993. Also note that sample sizes may change somewhat from article to article as old data are refined, new data are gathered or located, participants die, or time periods change.

LESLIE R. MARTIN, PhD is Professor of Psychology at La Sierra University.

JOAN S. TUCKER, PhD is Behavioral Scientist at the RAND Corporation.

MICHAEL H. CRIQUI, MD, MPH is Professor of Medicine, and Professor of Family and Preventive Medicine at the University of California, San Diego.

MARGARET L. KERN, MA is a graduate student in psychology at the University of California, Riverside.

CHANDRA A. REYNOLDS, PhD (Principal Investigator of NIA grant AG027001), is Associate Professor of Psychology at the University of California, Riverside.

---